

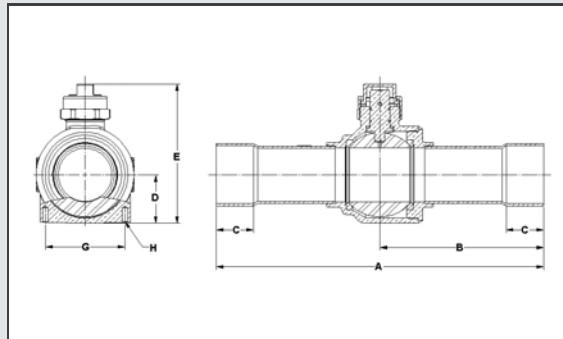

### Features:

- Design Pressure (DP) / Maximum abnormal pressure (MAP): Up to 775 psig, 53 bar
- Continuous operating temperature (COT): -40°F/300°F, -40°C/149°C
- Contact factory or visit website for compatibility with CFC, HCFC, HFC and HFO refrigerants and oils
- Full port construction to match line size ID
- Internally equalized ball design
- Rupture-proof encapsulated stem
- Bi-directional flow
- MCM Seal Technology
- UL/cUL Listed, Conforms to Pressure Equipment Directive 2014/68/EU



Part Number	Size		Cv	Kv	A		B		C Min		D		E		G **		H **		Port (in)	MAP		Wt		Seal Cap Kit
	in	mm			in	mm	in	mm	in	mm	in	mm	in	mm	in	mm	in	mm		psi	bar	lb	kg	
AP17859	‡	1/4	6	1.0	1	5.50	140	2.98	76	0.31	8	0.54	14	2.23	57	0.87	22	M4 X 0.7	0.50	775	53	0.48	0.22	A 17842
AP17860C	‡	3/8	10	4.3	4	5.50	140	2.98	76	0.31	8	0.54	14	2.23	57	0.87	22	M4 X 0.7	0.50	775	53	0.48	0.22	A 17842
AP17861C	‡	1/2	13	6.2	5	6.35	161	3.41	87	0.38	10	0.54	14	2.23	57	0.87	22	M4 X 0.7	0.50	775	53	0.53	0.24	A 17842
AP17862C	‡	5/8	17	12.1	10	6.35	161	3.41	87	0.50	13	0.54	14	2.23	57	0.87	22	M4 X 0.7	0.50	775	53	0.50	0.23	A 17842
AP17863	‡	3/4	19	19.0	16	7.45	189	3.89	99	0.62	16	0.72	18	2.66	68	1.18	30	M4 X 0.7	0.75	775	53	0.88	0.40	A 17843
AP17864C	‡	7/8	22	27.5	24	7.45	189	3.89	99	0.75	19	0.72	18	2.66	68	1.18	30	M4 X 0.7	0.75	775	53	0.93	0.42	A 17843
AP17865	‡	1 1/8	29	54.0	47	8.42	214	4.21	107	0.91	23	1.00	25	3.15	80	1.50	38	M4 X 0.7	1.00	775	53	1.61	0.73	A 17843
A 17866		1 3/8	35	89.1	77	10.00	254	5.00	127	0.97	25	1.17	30	3.72	94	1.89	48	M6 X 1.0	1.25	775	53	2.59	1.17	A 17844
A 17867		1 5/8	41	114.0	99	11.00	279	5.50	140	1.09	28	1.38	35	4.12	105	2.17	55	M6 X 1.0	1.50	775	53	3.64	1.65	A 17844
A 17868		2 1/8	54	244.0	211	12.00	305	6.00	152	1.34	34	1.79	45	5.14	131	2.91	74	M6 X 1.0	2.00	700	48	8.02	3.64	A 17845
A 17869		2 5/8	67	401.0	347	13.50	343	6.75	171	1.47	37	2.19	56	5.92	150				2.44	700	48	13.40	6.08	A 17845
A 17870		3 1/8	79	553.0	478	16.00	406	8.00	203	1.66	42	2.69	68	7.03	179				3.00	700	48	21.31	9.67	A 17846
A 17871	*	2 5/8	67	230.0	199	12.00	305	6.00	152	1.47	37	1.79	45	5.14	131	2.91	74	M6 X 1.0	2.00	700	48	8.46	3.84	A 17845
A 17872	*	3 1/8	79	143.0	124	12.00	305	6.00	152	1.66	42	1.79	45	5.14	131	2.91	74	M6 X 1.0	2.00	700	48	9.12	4.13	A 17845
B 34909	***	3 5/8	92			13.10	333	6.50	165	1.91	49	2.69	68	7.03	179				3.00	700	48	19.91	9.03	A 17846
B 34910	***	4 1/8	105			14.50	368	7.20	183	2.16	55	2.69	68	7.03	179				3.00	700	48	21.00	9.53	A 17846

\* Reduced Port

\*\* Where Applicable

\*\*\* Consult Factory

‡ Standard product offering includes drilled/ tapped feature

Prefix AP Drilled/ tapped



### Features:

- Design Pressure (DP) / Maximum abnormal pressure (MAP): Up to 775 psig, 53 bar
- Continuous operating temperature (COT): -40°F/300°F, -40°C/149°C
- Contact factory or visit website for compatibility with CFC, HCFC, HFC and HFO refrigerants and oils
- Full port construction to match line size ID
- Internally equalized ball design
- Rupture-proof encapsulated stem
- Bi-directional flow
- MCM Seal Technology
- UL/cUL Listed, Conforms to Pressure Equipment Directive 2014/68/EU

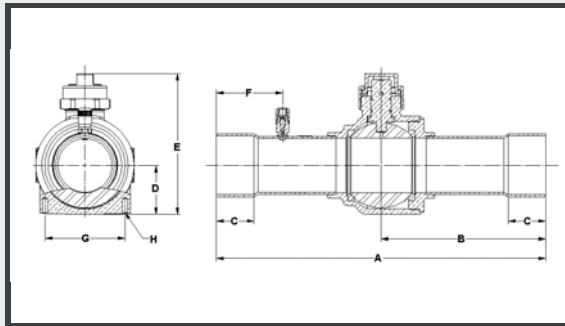

Part Number	Size		Cv	Kv	A		B		C Min		D		E		F		G **		H **		Port (in)	MAP		Wt		Seal Cap Kit
	in	mm			in	mm	in	mm	in	mm	in	mm	in	mm	in	mm	in	mm	in	mm		psig	bar	lb	kg	
AQ17859 ‡	1/4	6	1.0	1	5.50	140	2.98	76	0.31	8	0.54	14	2.23	57	1.16	29	0.87	22	M4 X 0.7	0.50	775	53	0.52	0.23	A 17842	
AQ17860C ‡	3/8	10	4.3	4	5.50	140	2.98	76	0.31	8	0.54	14	2.23	57	1.16	29	0.87	22	M4 X 0.7	0.50	775	53	0.52	0.24	A 17842	
AQ17861C ‡	1/2	13	6.2	5	6.35	161	3.41	87	0.38	10	0.54	14	2.23	57	1.21	31	0.87	22	M4 X 0.7	0.50	775	53	0.53	0.24	A 17842	
AQ17862C ‡	5/8	17	12.1	10	6.35	161	3.41	87	0.50	13	0.54	14	2.23	57	1.35	34	0.87	22	M4 X 0.7	0.50	775	53	0.54	0.24	A 17842	
AQ17863 ‡	3/4	19	19.0	16	7.45	189	3.89	99	0.62	16	0.72	18	2.66	68	1.47	37	1.18	30	M4 X 0.7	0.75	775	53	0.92	0.42	A 17843	
AQ17864C ‡	7/8	22	27.5	24	7.45	189	3.89	99	0.75	19	0.72	18	2.66	68	1.60	41	1.18	30	M4 X 0.7	0.75	775	53	0.96	0.43	A 17843	
AQ17865 ‡	1 1/8	29	54.0	47	8.42	214	4.21	107	0.91	23	1.00	25	3.15	80	1.74	44	1.50	38	M4 X 0.7	1.00	775	53	1.66	0.75	A 17843	
AC17866	1 3/8	35	89.1	77	10.00	254	5.00	127	0.97	25	1.17	30	3.72	94	2.04	52	1.89	48	M6 X 1.0	1.25	775	53	2.62	1.19	A 17844	
AC17867	1 5/8	41	114.0	99	11.00	279	5.50	140	1.09	28	1.38	35	4.12	105	2.25	57	2.17	55	M6 X 1.0	1.50	775	53	3.68	1.67	A 17844	
AC17868	2 1/8	54	244.0	211	12.00	305	6.00	152	1.34	34	1.79	45	5.14	131	2.41	61	2.91	74	M6 X 1.0	2.00	700	48	8.09	3.67	A 17845	
AC17869	2 5/8	67	401.0	347	13.50	343	6.75	171	1.47	37	2.19	56	5.92	150	2.85	72				2.44	700	48	13.81	6.26	A 17845	
AC17870	3 1/8	79	553.0	478	16.00	406	8.00	203	1.66	42	2.69	68	7.03	179	3.41	87				3.00	700	48	21.42	9.72	A 17846	
AC17871 *	2 5/8	67	230.0	199	12.00	305	6.00	152	1.47	37	1.79	45	5.14	131	2.48	63	2.91	74	M6 X 1.0	2.00	700	48	8.71	3.95	A 17845	
AC17872 *	3 1/8	79	143.0	124	12.00	305	6.00	152	1.66	42	1.79	45	5.14	131	2.66	68	2.91	74	M6 X 1.0	2.00	700	48	9.23	4.18	A 17845	

\* Reduced Port

\*\* Where Applicable

\*\*\* Consult Factory

‡ Standard product offering includes drilled/ tapped feature

Prefix AQ Drilled/ tapped



### Features:

- Design Pressure (DP) / Maximum abnormal pressure (MAP): 775 psig, 53 bar
- Continuous operating temperature (COT): -40°F/300°F, -40°C/149°C
- Contact factory or visit website for compatibility with CFC, HCFC, HFC and HFO refrigerants and oils
- Full port construction to match line size ID
- Internally equalized ball design
- Rupture-proof encapsulated stem
- MCM Seal Technology

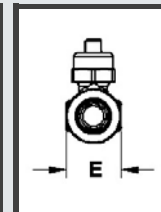
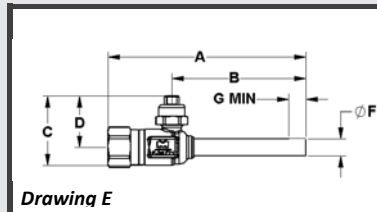
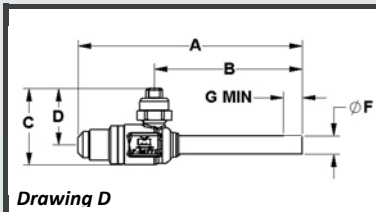
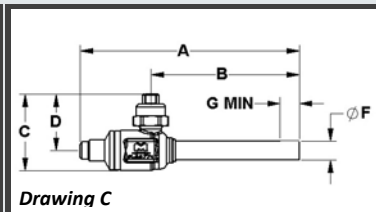
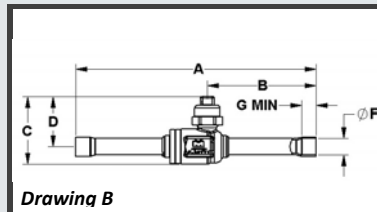
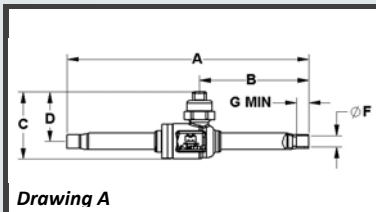

### Solder

Part Number	Size	A	B	C	D	E	F	G Min	Wt	Drawing	2 Piece Seal Cap Assembly
	in	in mm	in mm	in mm	in mm	in mm	in mm	in mm	lb kg		
A 17855	1/4 ODS	5.50 140	2.50 64	1.54 39	1.14 29	0.81 21	0.250 6	0.25 6	0.25 0.12	A	A 17841
A 17856	3/8 ODS	5.50 140	2.50 64	1.54 39	1.14 29	0.81 21	0.375 10	0.31 8	0.26 0.12	B	A 17841

### FL x ODE

Part Number	Size	A	B	C	D	E	F	G Min	Wt	Drawing	Flare Fitting Seal Cap	Valve Core **	Flare Fitting Seal Cap Kit ***	2 Piece Seal Cap Assembly
	in	in mm	in mm	in mm	in mm	in mm	in mm	in mm	lb kg					
A 18673	1/4 FL X 3/8 ODE	4.38 111	2.97 75	1.54 39	1.14 29	0.81 21	0.375 10	0.38 10	0.26 0.12	C	A 16447	P 25998	A 18726	A 17841
A 18674	3/8 FL X 3/8 ODE	4.50 114	2.97 75	1.54 39	1.14 29	0.81 21	0.375 10	0.38 10	0.28 0.13	D	A 16448			A 17841

### NPTFI X ODE

Part Number	Size	A	B	C	D	E	F	G Min	Wt	Drawing	Plug for 1/4 NPTF	2 Piece Seal Cap Assembly
	in	in mm	in mm	in mm	in mm	in mm	in mm	in mm	lb kg			
A 18675	1/4 NPTFI X 3/8 ODE	4.38 111	2.97 75	1.54 39	1.14 29	0.81 21	0.375 10	0.38 10	0.28 0.13	E	P 34707	A 17841

- \* Assembled finger tight
- \*\* Installation torque 1-3 in/lbs
- \*\*\* Includes seal cap and valve core
- 1) Stem torque to rotate ball: 15 in-lbs maximum
- 2) Torque for installing ball valves with 1/4" flare connection: 8 – 10 ft-lbs
- 3) Torque for installing ball valves with 3/8" flare connection: 15 - 25 ft-lbs



### Features:

- Design Pressure (DP) / Maximum abnormal pressure (MAP): 2031 psi, 140 bar
- Continuous operating temperature (COT): -40°F/300°F, -40°C/149°C
- Designed for transcritical CO2 systems
- Bi-directional flow
- Brass body with copper-iron alloy connections
- Bleed hole in ball allows for the support of gas pressure without stressing other components
- Full port construction to match line size
- Rupture-proof, internally-loaded stem
- Specially selected o-ring material compatible for CO2 operating conditions
- UL/cUL Listed, conforms to Pressure Equipment Directive 2014/68/EU and EN 378-2

### Solder Cup Connection

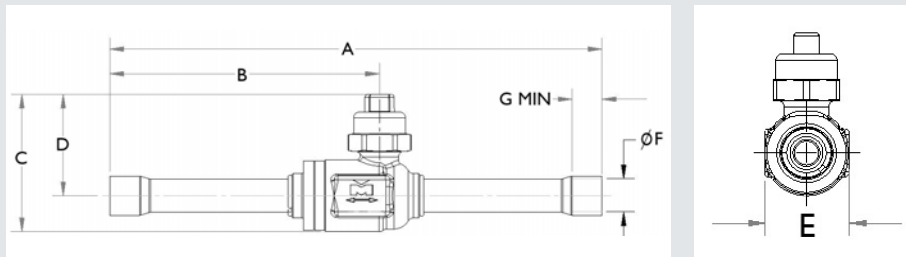

Part Number	Size		Cv	Kv	A		B		C Min		D		E		G **		H **	Port (in)	Wt		Seal Cap Kit
	in	mm			in	mm	in	mm	in	mm	in	mm	in	mm	in	mm			lb	kg	
A 17856XHP	3/8	10	4.3	4	5.50	140	3.01	76	1.54	39	1.14	29	0.80	20	0.31	8	M4 X 0.7	0.50	0.24	0.11	A 17842
A 17861XHP	1/2	13	6.2	5	6.35	161	3.41	87	2.23	57	1.69	43	1.14	29	0.38	10	M4 X 0.7	0.50	0.54	0.24	A 17842
A 17862XHP	5/8	17	12.1	10	6.35	161	3.41	87	2.23	57	1.69	43	1.14	29	0.50	13	M4 X 0.7	0.50	0.53	0.24	A 17842
A 17864XHP	7/8	22	27.5	24	7.45	189	3.88	99	3.35	85	2.07	53	1.76	45	0.75	19	M4 X 0.7	0.75	1.59	0.72	A 17843
A 17865XHP	1 1/8	29	54.0	47	8.41	214	4.33	110	3.97	101	2.50	64	2.26	57	0.91	23	M4 X 0.7	1.00	3.06	1.39	A 17843

### Straight End Connection

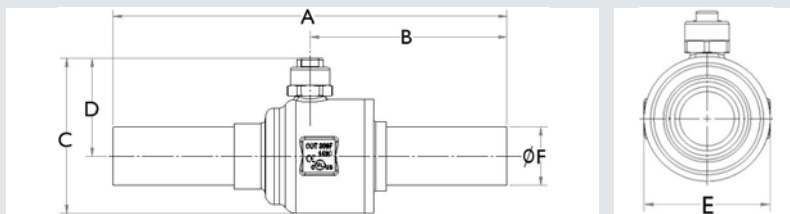

Part Number	Size		Cv	Kv	A		B		C Min		D		E		G **	H **	Port (in)	Wt		Seal Cap Kit	
	in	mm			in	mm	in	mm	in	mm	in	mm	in	mm				in	mm		lb
AF17866XHP	1 3/8	35	89.1	77	10.00	254	5.00	127	3.92	100	2.55	65	2.76	70	0.00	0	M6 X 1.0	1.25	4.55	2.06	A 17844
AF17867XHP	1 5/8	41	114.0	99	11.00	279	5.50	140	4.33	110	2.74	70	3.18	81	0.00	0	M6 X 1.0	1.50	6.74	3.06	A 17844
AF17868XHP	2 1/8	54	244.0	211	12.00	305	6.00	152	5.53	140	3.47	88	4.14	105	0.00	0	M6 X 1.0	2.00	13.66	6.20	A 17845

*XHP Female x Female Coupling available through Mueller Streamline*



**Features:**

- Design Pressure (DP) / Maximum abnormal pressure (MAP): 60 bar
- Continuous operating temperature (COT): -40°F/300°F, -40°C/149°C
- Designed for subcritical CO2 systems
- Bi-directional flow
- Brass body with copper-iron alloy connections
- Full port construction to match line size
- Rupture-proof, internally-loaded stem
- Specially selected o-ring material compatible for CO2 operating conditions
- UL/cUL Listed, conforms to Pressure Equipment Directive 2014/68/EU and EN 378-2

**Solder Connections**

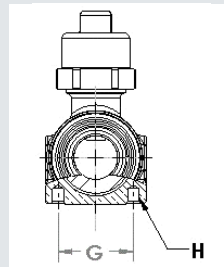
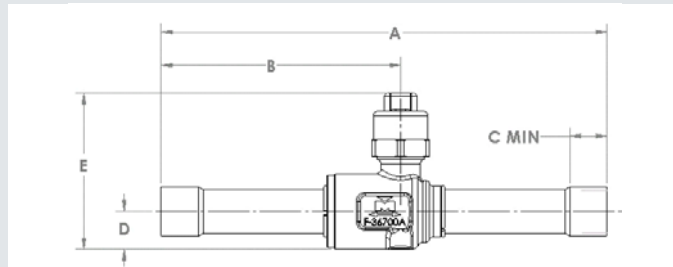

Part Number	Size		Cv	Kv	A		B		C Min		D		E		G **		H **	Port (in)	Wt		Seal Cap Kit
	in	mm			in	mm	in	mm	in	mm	in	mm	in	mm	in	mm			lb	kg	
AP17859HP	1/4	6	1.0	1	5.50	140	2.98	76	0.31	8	0.54	14	2.23	57	0.87	22	M4 X 0.7	0.50	0.67	0.30	A 17842
AP17860HP	3/8	10	4.3	4	5.50	140	2.98	76	0.31	8	0.54	14	2.23	57	0.87	22	M4 X 0.7	0.50	0.48	0.22	A 17842
AP17861HP	1/2	13	6.2	5	6.35	161	3.41	87	0.38	10	0.54	14	2.23	57	0.87	22	M4 X 0.7	0.50	0.53	0.24	A 17842
AP17862HP	5/8	17	12.1	10	6.35	161	3.41	87	0.50	13	0.54	14	2.23	57	0.87	22	M4 X 0.7	0.50	0.50	0.23	A 17842
AP17863HP	3/4	19	19.0	16	7.45	189	3.89	99	0.62	16	0.72	18	2.66	68	1.18	30	M4 X 0.7	0.75	1.40	0.64	A 17843
AP17864HP	7/8	22	27.5	24	7.45	189	3.89	99	0.75	19	0.72	18	2.66	68	1.18	30	M4 X 0.7	0.75	0.93	0.42	A 17843
AP17865HP	1 1/8	29	54.0	47	8.41	214	4.21	107	0.91	23	1.00	25	3.15	80	1.50	38	M4 X 0.7	1.00	1.61	0.73	A 17843

**NPTFI X ODE Connections**

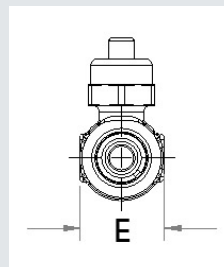
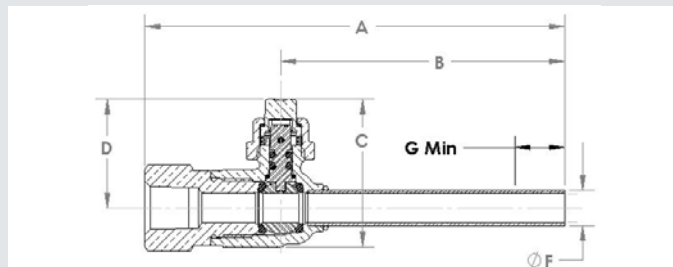

Part Number	Size		Cv	Kv	A		B		C Min		D		E		G **		Wt		Seal Cap Kit
	in	mm			in	mm	in	mm	in	mm	in	mm	in	mm	in	mm	lb	kg	
A 18675HP	1/4	6	0.0	0	4.38	111	2.97	75	1.54	39	1.14	29	0.81	21	0.38	10	0.29	0.13	A 17841

\*\* Where Applicable



**Features:**

- Design Pressure (DP) / Maximum abnormal pressure (MAP): 775 psig, 53 bar
- Continuous operating temperature (COT): -40°F/300°F, -40°C/149°C
- Contact factory or visit website for compatibility with CFC, HCFC, HFC and HFO refrigerants and oils
- Full port construction to match line size ID
- Internally equalized ball design
- Rupture-proof encapsulated stem
- MCM Seal Technology
- UL/cUL Listed, Conforms to Pressure Equipment Directive 2014/68/EU

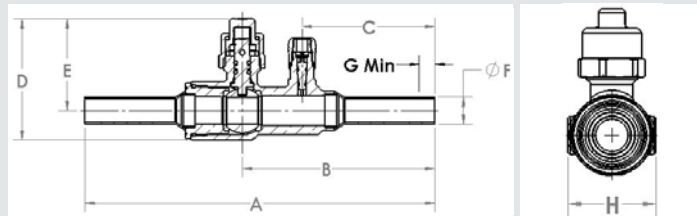

Part Number	Size		Cv	Kv	A		B		C		D		E		F		G Min		Wt		Seal Cap Kit
	in	mm			in	mm	in	mm	in	mm	in	mm	in	mm	in	mm	in	mm	lb	kg	
A 18959	1/4	6	1.0	1	6.51	165	3.62	92	2.52	64	2.23	57	1.69	43	0.25	6	0.38	10	0.69	0.31	A 17842
A 18960	3/8	10	4.0	3	6.15	156	3.44	87	2.34	59	2.23	57	1.69	43	0.38	10	0.38	10	0.61	0.28	A 17842
A 18961	1/2	13	5.0	4	6.43	163	3.54	90	2.44	62	2.23	57	1.69	43	0.50	13	0.44	11	0.59	0.27	A 17842
A 18962	5/8	17	10.0	9	6.07	154	3.36	85	2.26	57	2.23	57	1.69	43	0.63	16	0.56	14	0.62	0.28	A 17842

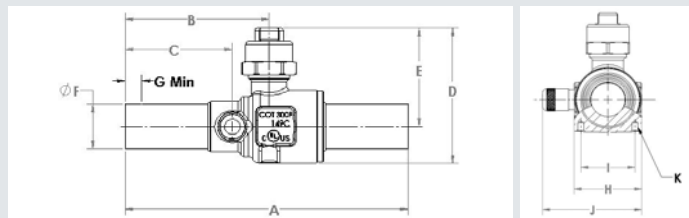

Part Number	Size		Cv	Kv	A		B		C		D		E		F		G Min		H		I		J		K		Wt		Seal Cap Kit
	in	mm			in	mm	in	mm	in	mm	in	mm	in	mm	in	mm	in	mm	in	mm	in	mm	in	mm	in	mm	in	mm	
A 18963	3/4	19	19.0	16	6.12	155	3.11	79	2.39	61	2.66	68	1.94	49	0.75	19	0.69	18	2.17	55	1.18	30	2.17	55	M4 X 0.7	0.86	0.39	A 17843	
A 18964	7/8	22	27.5	24	5.54	141	2.82	72	2.10	53	2.66	68	1.94	49	0.88	22	0.81	21	2.17	55	1.18	30	2.17	55	M4 X 0.7	0.87	0.39	A 17843	
A 18965	1 1/8	29	54.0	47	7.62	194	4.15	105	3.10	79	3.15	80	2.15	55	1.13	29	0.97	25	2.58	66	1.50	38	2.58	66	M4 X 0.7	1.65	0.75	A 17843	
A 18966	1 3/8	35	89.0	77	7.74	197	4.10	104	3.06	78	3.75	95	2.55	65	1.38	35	1.03	26	2.86	73	1.89	48	2.86	73	M4 X 0.7	2.37	1.07	A 17843	



**Features:**

- Design Pressure (DP) / Maximum abnormal pressure (MAP): 775 psig, 53 bar
- Continuous operating temperature (COT): -40°F/300°F, -40°C/149°C
- Contact factory or visit website for compatibility with CFC, HCFC, HFC and HFO refrigerants and oils
- Full port construction to match line size ID
- Internally equalized ball design
- Rupture-proof encapsulated stem
- MCM Seal Technology
- UL/cUL Listed, Conforms to Pressure Equipment Directive 2014/68/EU

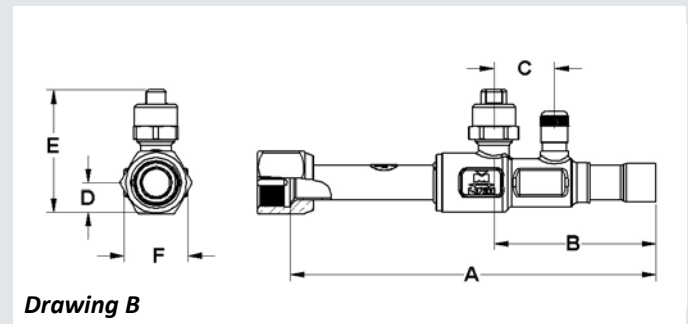
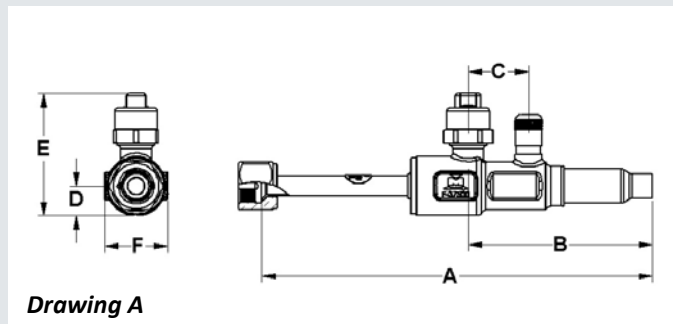

Valve Part Number	Valve Insulation Kit Part Number	Size		A		B		C		D		E		F		Wt		Drawing
		in	mm	in	mm	in	mm	in	mm	in	mm	in	mm	in	mm	lb	kg	
A 18941	A 18611U	1/4	6	7.17	182	3.36	85	1.10	28	0.54	14	2.23	57	1.16	29	0.64	0.29	A
A 18942	A 18612U	3/8	10	7.12	181	3.36	85	1.10	28	0.54	14	2.23	57	1.16	29	0.70	0.32	A
A 18943	A 18613U	1/2	13	6.71	170	2.94	75	1.10	28	0.54	14	2.23	57	1.16	29	0.73	0.33	A
A 18944	A 18614U	5/8	17	6.64	169	2.94	75	1.10	28	0.54	14	2.23	57	1.16	29	0.79	0.36	B

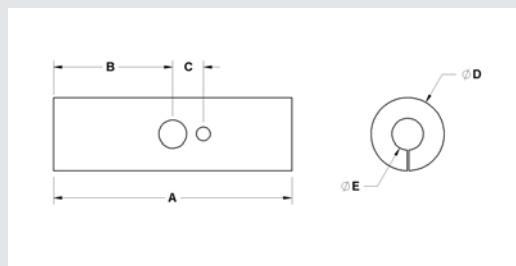

Insulation Part No.	A (in)	B (in)	C (in)	D (in)	E (in)	Thickness (in)	Wt(lb)
MSBVINSCEN	8.56	4.28	1.10	2.63	1.13	0.75	0.02



### Features:

- Design Pressure (DP) / Maximum abnormal pressure (MAP): 775 psig, 53 bar
- Continuous operating temperature (COT): -40°F/300°F, -40°C/149°C
- Contact factory or visit website for compatibility with CFC, HCFC, HFC and HFO refrigerants and oils
- Full port construction to match line size ID
- Internally equalized ball design
- Rupture-proof encapsulated stem
- MCM Seal Technology
- UL/cUL Listed, Conforms to Pressure Equipment Directive 2014/68/EU

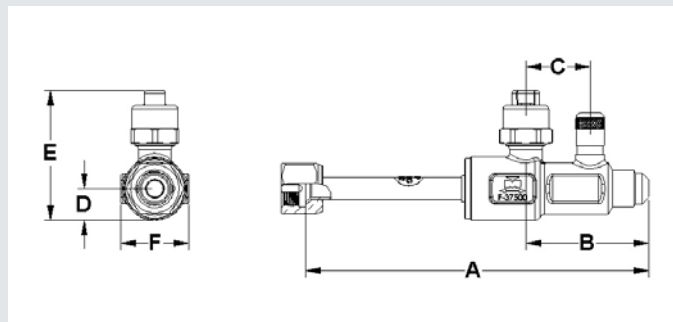

Valve Part Number	Valve Insulation Kit Part Number	Size		A		B		C		D		E		F		Wt	
		in	mm	in	mm	in	mm	in	mm	in	mm	in	mm	in	mm	lb	kg
A 18945	A 18567U	1/4	6	5.86	149	2.05	52	1.10	28	0.54	14	2.23	57	1.16	29	0.62	0.28
A 18946	A 18568U	3/8	10	5.86	149	2.10	53	1.10	28	0.54	14	2.23	57	1.16	29	0.69	0.31
A 18947	A 18569U	1/2	13	5.98	152	2.21	56	1.10	28	0.54	14	2.23	57	1.16	29	0.76	0.34
A 18948	A 18570U	5/8	17	5.98	152	2.28	58	1.10	28	0.54	14	2.23	57	1.16	29	0.84	0.38
A 18949	A 18652U	3/8 F X 1/4 M		5.81	148	2.05	52	1.10	28	0.54	14	2.23	57	1.16	29	0.68	0.31
A 18950	A 18653U	5/8 F X 1/2 M		5.91	150	2.21	56	1.10	28	0.54	14	2.23	57	1.16	29	0.82	0.37

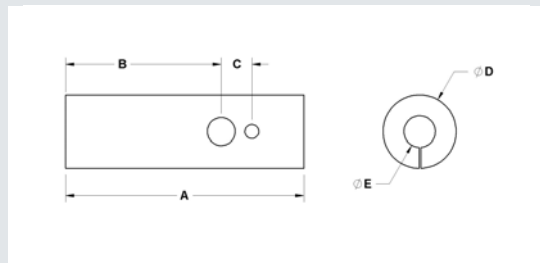

Insulation Part No.	A (in)	B (in)	C (in)	D (in)	E (in)	Thickness (in)	Wt(lb)
MSBVINS	8.56	6.56	1.10	2.63	1.13	0.75	0.10





### Features:

- Design Pressure (DP) / Maximum abnormal pressure (MAP): 775 psig, 53 bar
- Continuous operating temperature (COT): -40°F/300°F, -40°C/149°C
- Contact factory or visit website for compatibility with CFC, HCFC, HFC and HFO refrigerants and oils
- Full port construction to match line size ID
- Internally equalized ball design
- Rupture-proof encapsulated stem
- MCM Seal Technology
- UL/cUL Listed, Conforms to Pressure Equipment Directive 2014/68/EU

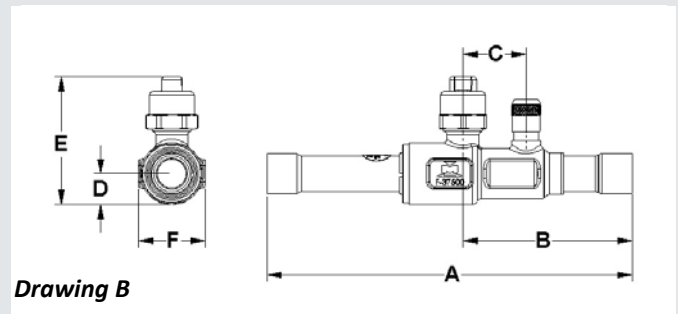
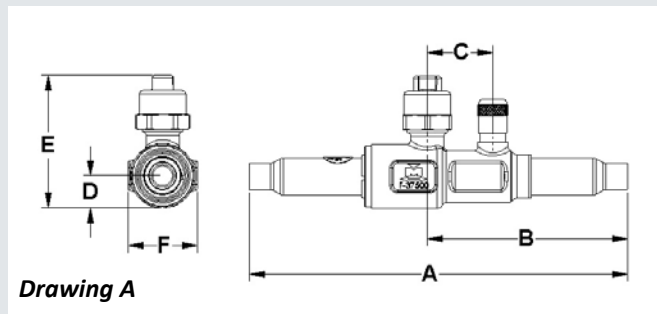

Valve Part Number	Valve Insulation Kit Part Number	Size		A		B		C		D		E		F		Wt		Drawing
		in	mm	in	mm	in	mm	in	mm	in	mm	in	mm	in	mm	lb	kg	
A 18937	A 18571U	1/4	6	6.35	161	3.36	85	1.10	28	0.54	14	2.23	57	1.16	29	0.60	0.27	A
A 18938	A 18572U	3/8	10	6.35	161	3.36	85	1.10	28	0.54	14	2.23	57	1.16	29	0.62	0.28	A
A 18939	A 18573U	1/2	13	6.35	161	2.94	75	1.10	28	0.54	14	2.23	57	1.16	29	0.61	0.28	A
A 18940	A 18574U	5/8	17	6.35	161	2.94	75	1.10	28	0.54	14	2.23	57	1.16	29	0.61	0.27	B

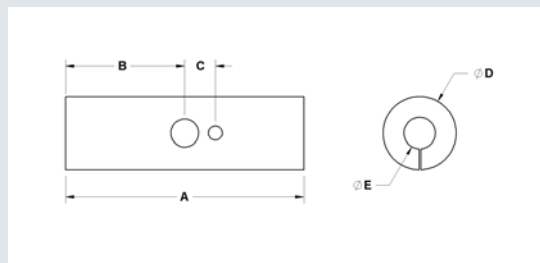

Insulation Part No.	A (in)	B (in)	C (in)	D (in)	E (in)	Thickness (in)	Wt(lb)
MSBVINSCEN	8.56	4.28	1.10	2.63	1.13	0.75	0.02



### Features:

- Design Pressure (DP) / Maximum abnormal pressure (MAP): 700 psig, 48 bar
- Continuous operating temperature (COT): -40°F/300°F, -40°C/149°C
- Contact factory or visit website for compatibility with CFC, HCFC, HFC and HFO refrigerants and oils
- Full port construction to match line size ID
- Internally equalized ball design
- Rupture-proof encapsulated stem
- MCM Seal Technology
- UL/cUL Listed, Conforms to Pressure Equipment Directive 2014/68/EU

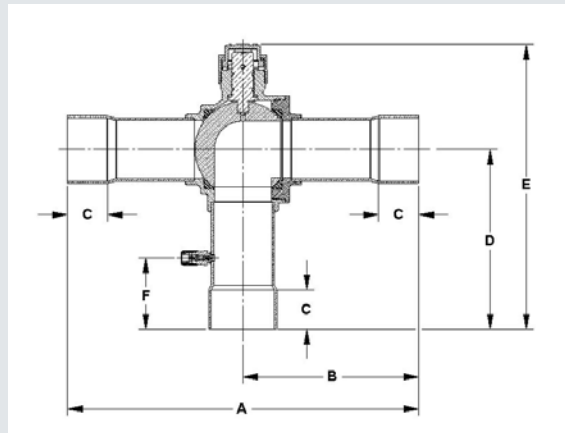

Part Number	Size		Cv	Kv	A		B		C		D		E		F		Port (in)	Wt		Seal Cap Kit
	in	mm			in	mm	in	mm	in	mm	in	mm	in	mm	in	mm		lb	kg	
AU17860	3/8	10	2.23	2	5.50	140	2.97	75	0.31	8	2.61	66	4.16	106	1.16	29	0.50	0.73	0.33	A 17842
AU17861	1/2	13	3.94	3	6.38	162	3.42	87	0.38	10	3.05	77	4.60	117	1.21	31	0.50	0.74	0.33	A 17842
AU17862	5/8	17	4.63	4	6.38	162	3.42	87	0.50	13	3.05	77	4.60	117	1.35	34	0.50	0.74	0.34	A 17842
AU17863	3/4	19	11.90	10	7.47	190	3.91	99	0.62	16	3.65	93	5.86	149	1.47	37	0.75	1.40	0.64	A 17843
AU17864	7/8	22	10.89	9	7.47	190	3.91	99	0.75	19	3.65	93	5.86	149	1.60	41	0.75	1.52	0.69	A 17843
AU17865	1 1/8	29	19.33	17	8.41	214	4.33	110	0.91	23	4.01	102	6.39	162	1.74	44	1.00	2.82	1.28	A 17844
A 17545	1 3/8	35	31.06	27	10.00	254	5.07	129	0.97	25	4.92	125	7.89	200	2.04	52	1.25	4.97	2.25	A 17845
A 17546	1 5/8	41	44.69	39	11.00	279	5.53	140	1.09	28	5.46	139	8.61	219	2.25	57	1.50	7.17	3.25	A 17845
AU17868	2 1/8	54	76.32	66	11.86	301	5.95	151	1.34	34	6.06	154	9.58	243	2.41	61	1.93	8.27	3.75	A 17845
AU17871 *	2 5/8	67	69.85	60	11.90	302	5.97	152	1.47	37	6.08	154	9.60	244	2.48	63	1.93	8.80	3.99	A 17845

\* Reduced Port



### Features:

- Design Pressure (DP) / Maximum abnormal pressure (MAP): Up to 775 psig, 53 bar
- Power Supply: 24 VAC
- Actuator Ambient Temperature: -25°F to 130°F, -32°C to 54°C
- Contact factory or visit website for compatibility with CFC, HCFC, HFC and HFO refrigerants and oils
- Valve Refrigerant Temperature: -40°F to 300°F, -40°C to 149°C
- Full shutoff capability
- Gradual open/close stops line hammer
- Remote operating capability
- Removable actuator for quick change replacement
- Manual override and valve positioning
- Electronic overload protection
- UL/cUL Listed, Conforms to Pressure Equipment Directive 2014/68/EU

### Actuated Standard

Part Number	Size		Cv	Kv	A		B		C Min		D		MAP		Wt		Motor	Hub Kit	Actuator Kit***	Heater
	in	mm			in	mm	in	mm	in	mm	in	mm	psig	bar	lb	kg				
AW17861	1/2	13	6.20	5	4.00	102	2.36	60	3.70	94	2.76	70	775	53	2.21	1.00	1	A 18389	A 18390	
AW17862	5/8	17	12.10	10	4.00	102	2.36	60	3.70	94	2.76	70	775	53	2.38	1.08	1	A 18389	A 18390	
AW17863	3/4	19	19.00	16	4.21	107	2.36	60	3.70	94	2.76	70	775	53	2.40	1.09	1	A 18391	A 18392	
AW17864	7/8	22	27.50	24	4.21	107	2.36	60	3.70	94	2.76	70	775	53	2.42	1.10	1	A 18391	A 18392	
AW17865	1 1/8	29	54.00	47	4.58	116	2.36	60	3.70	94	2.76	70	775	53	3.10	1.41	1	A 18391	A 18392	
AW17866	1 3/8	35	89.10	77	5.05	128	2.36	60	5.91	150	3.19	81	775	53	5.53	2.51	2	A 18393	A 18394	A 18366
AW17867	1 5/8	41	114.00	99	5.34	136	2.36	60	5.91	150	3.19	81	775	53	6.94	3.15	2	A 18393	A 18394	A 18366
AW17868	2 1/8	54	244.00	211	6.42	163	2.66	68	8.94	227	3.94	100	700	48	13.14	5.96	3	A 18368	A 18395	A 18367
AW17869	** 2 5/8	67	401.00	347	9.45	240	5.30	135	8.94	227	3.94	100	700	48	23.40	10.61	4	A 18764	A 18765	A 18367 (2)
AW17870	** 3 1/8	79	553.00	478	9.99	254	5.30	135	8.94	227	3.94	100	700	48	31.40	14.24	4	A 18400	A 18401	A 18367 (2)
AW17871	* 2 5/8	67	230.00	199	6.42	163	2.66	68	8.94	227	3.94	100	700	48	13.56	6.15	3	A 18368	A 18395	A 18367
AW17872	* 3 1/8	79	143.00	124	6.42	163	2.66	68	8.94	227	3.94	100	700	48	14.24	6.46	3	A 18368	A 18395	A 18367

### Actuated 3-Way

Part Number	Size		Cv	Kv	A		B		C Min		D		MAP		Wt		Motor	Hub Kit	Actuator Kit***	Heater
	in	mm			in	mm	in	mm	in	mm	in	mm	psig	bar	lb	kg				
AY17861	1/2	13	3.90	3	4.18	106	2.36	60	3.70	94	2.76	70	700	48	2.28	1.03	1	A 18389	A 18390	
AY17862	5/8	17	4.60	4	4.18	106	2.36	60	3.70	94	2.76	70	700	48	2.39	1.08	1	A 18389	A 18390	
AY17863	3/4	19	11.90	10	4.50	114	2.36	60	3.70	94	2.76	70	700	48	3.50	1.59	1	A 18391	A 18392	
AY17864	7/8	22	10.90	9	4.50	114	2.36	60	3.70	94	2.76	70	700	48	3.25	1.47	1	A 18391	A 18392	
AY17865	1 1/8	29	19.30	17	5.02	128	2.36	60	5.91	150	3.19	81	700	48	5.73	2.60	2	A 18393	A 18394	A 18366
A 17810	1 3/8	35	31.10	27	5.44	138	2.36	60	5.91	150	3.19	81	700	48	8.13	3.69	2	A 18368	A 18396	A 18366
A 17811	1 5/8	41	44.70	39	6.22	158	2.66	68	8.94	227	3.94	100	700	48	12.00	5.44	3	A 18368	A 18395	A 18367
AY17868	2 1/8	54	76.30	66	6.54	166	2.66	68	8.94	227	3.94	100	700	48	13.23	6.00	3	A 18368	A 18395	A 18367
AY17871	* 2 5/8	67	69.90	60	6.54	166	2.66	68	8.94	227	3.94	100	700	48	14.09	6.39	3	A 18368	A 18395	A 18367
AY17872	* 3 1/8	79	58.20	50	6.54	166	2.66	68	8.94	227	3.94	100	700	48	14.64	6.64	3	A 18368	A 18395	A 18367

\* Reduced Port

\*\* Consists of two stacked motors operating in tandem

\*\*\* Actuator Kit includes Motor and Hub

Prefix AWS Actuator includes auxillary switch

Prefix AYS Actuator includes auxillary switch

Suffix -KIT Weatherproof Enclosure Kit includes ball valve, actuator and hub kit with enclosure

Warning Heater assembly required for low temperature applications

Warning Motors not for use in wet or applications where moisture will condense on motor

# CYCLEMASTER® Ball Valves Actuated



Tonnage calculations are based on the following conditions:  
 Evaporator temperature: 40°  
 Vapor temperature exiting evaporator: 10°F superheated  
 Liquid temperature entering evaporator: 100°F  
 Hot gas temperature: 140°F  
 Pressure drop across valve: 1 psig

## Motor Specifications

Motor Series	Torque (in-lb)	Power Consumption (VA)	Running Time (seconds)
1	44	2.5	90
2	132	3.0	125
3	310	7	125
4 **	620	12	125

## Actuated Standard

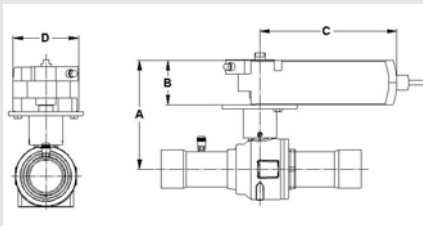

## Actuated 3-Way

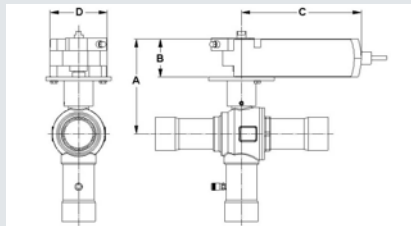

Part Number	Liquid Capacity (tons)					Suction Capacity (tons)					Hot Gas Capacity (tons)				
	R22	R134a	R404A/ R507	R407C	R410A	R22	R134a	R404A/ R507	R407C	R410A	R22	R134a	R404A/ R507	R407C	R410A
AW17861	19.0	17.7	12.2	18.13	17.8	2.7	2.1	2.2	2.52	3.1	3.9	3.2	3.2	4.05	4.5
AW17862	36.9	34.5	23.8	35.27	34.6	5.2	4.1	4.3	4.90	6.0	7.5	6.2	6.2	7.87	8.7
AW17863	58.0	54.1	37.4	55.40	54.4	8.1	6.4	6.8	7.69	9.5	11.8	9.7	9.7	12.37	13.7
AW17864	84.1	78.4	54.2	80.27	78.8	11.8	9.2	9.8	11.15	13.7	17.1	14.1	14.0	17.92	19.8
AW17865	165.3	154.3	106.5	157.86	154.9	23.2	18.1	19.4	21.92	27.0	33.7	27.7	27.6	35.24	38.9
AW17866	272.9	254.7	175.8	260.62	255.8	38.3	29.9	32.0	36.19	44.6	55.6	45.7	45.6	58.18	64.2
AW17867	348.7	325.3	224.6	332.95	326.8	49.0	38.2	40.8	46.23	57.0	71.1	58.4	58.3	74.33	82.1
AW17868	746.8	696.9	481.2	713.19	699.9	104.9	81.9	87.5	99.03	122.2	152.3	125.0	124.8	159.21	175.8
AW17869	1227.6	1145.5	791.0	1172.30	1150.5	172.4	134.6	143.8	162.78	200.8	250.3	205.5	205.2	261.71	289.0
AW17870	1693.7	1580.4	1091.3	1617.41	1587.4	237.9	185.8	198.4	224.58	277.0	345.3	283.5	283.1	361.08	398.7
AW17871	705.3	658.2	454.5	673.57	661.1	99.1	77.4	82.6	93.53	115.4	143.8	118.1	117.9	150.37	166.0
AW17872	439.3	409.9	283.0	419.50	411.7	61.7	48.2	51.5	58.25	71.9	89.6	73.5	73.4	93.65	103.4
AY17861	12.1	11.3	7.8	11.52	11.3	1.7	1.3	1.4	1.60	2.0	2.5	2.0	2.0	2.57	2.8
AY17862	14.2	13.2	9.1	13.54	13.3	2.0	1.6	1.7	1.88	2.3	2.9	2.4	2.4	3.02	3.3
AY17863	36.4	34.0	23.5	34.79	34.1	5.1	4.0	4.3	4.83	6.0	7.4	6.1	6.1	7.77	8.6
AY17864	33.3	31.1	21.5	31.84	31.2	4.7	3.7	3.9	4.42	5.5	6.8	5.6	5.6	7.11	7.8
AY17865	59.2	55.2	38.1	56.52	55.5	8.3	6.5	6.9	7.85	9.7	12.1	9.9	9.9	12.62	13.9
A 17810	95.1	88.7	61.3	90.81	89.1	13.4	10.4	11.1	12.61	15.6	19.4	15.9	15.9	20.27	22.4
A 17811	136.8	127.7	88.2	130.66	128.2	19.2	15.0	16.0	18.14	22.4	27.9	22.9	22.9	29.17	32.2
AY17868	233.7	218.0	150.6	223.14	219.0	32.8	25.6	27.4	30.98	38.2	47.6	39.1	39.1	49.81	55.0
AY17871	213.9	199.6	137.8	204.22	200.4	30.0	23.5	25.1	28.36	35.0	43.6	35.8	35.7	45.59	50.3
AY17872	178.2	166.2	114.8	170.13	167.0	25.0	19.5	20.9	23.62	29.1	36.3	29.8	29.8	37.98	41.9

## Bracket Kits

Part Number	Valve Size	A		B		Screw Thread Size (C)	Wt	
		(in)	(mm)	(in)	(mm)		(lb)	(kg)
B 35531	1/4 - 5/8	2.28	58	0.17	4.4	M4 X .07	0.03	0.02
B 35532	3/4 - 7/8	2.84	72	0.17	4.4	M4 X .07	0.03	0.02
B 35533	1 1/8	3.07	78	0.17	4.4	M4 X .07	0.04	0.02
B 35534	1 3/8	3.62	92	0.25	6.4	M6 X 1.0	0.05	0.02
B 35535	1 5/8	3.94	100	0.25	6.4	M6 X 1.0	0.05	0.02
B 35536	2 1/8	4.80	122	0.25	6.4	M6 X 1.0	0.06	0.02

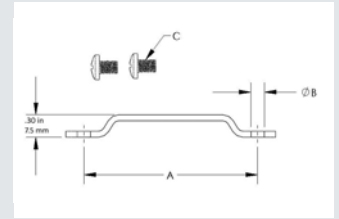

## Insulation Cover

Insulation	Valve Size	A (in)	B (in)	C (in)	D (in)	E (in)	Thickness (in)	Wt(lb)
38RBVINS	3/8	5.50	3.00	0.63	2.50	1.19	0.50	0.10
12RBVINS	1/2	6.38	3.44	0.63	2.50	1.19	0.50	0.10
58RBVINS	5/8	6.38	3.44	0.63	2.50	1.38	0.50	0.10
34RBVINS	3/4	7.44	3.88	0.88	3.06	1.63	1.09	0.10
78RBVINS	7/8	7.44	3.88	0.88	3.06	1.63	1.09	0.10
118RBVINS	1 1/8	8.44	4.31	1.13	3.63	1.75	1.25	0.10
138RBVINS	1 3/8	10.00	5.00	1.25	3.94	2.06	1.35	0.10
158RBVINS	1 5/8	11.00	5.50	1.44	4.56	2.25	1.56	0.32
218RBVINS	2 1/8	12.00	6.06	1.88	5.38	2.44	1.75	0.10
258RBVINS	2 5/8	13.50	6.81	2.25	6.25	2.88	2.00	0.82
MSBVINS	Holes Offset	8.56	6.56	1.10	2.63	1.13	0.75	0.10
MSBVINSCEN	Holes Centered	8.56	4.28	1.10	2.63	1.13	0.75	0.02

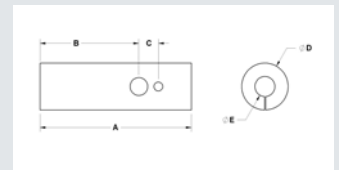
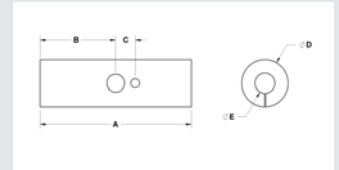





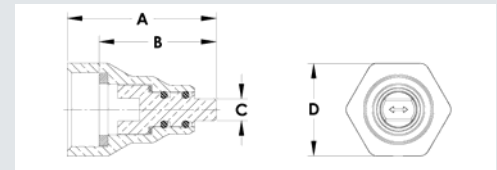

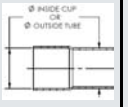
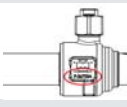
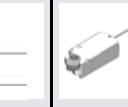

## Retrofit Cap

- Designed to replace existing caps on installed valves for the full range of CYCLEMASTER Ball Valve sizes 1/4" to 3 1/8"
- Large nut secures cap assembly to valve neck allowing center post to easily turn for on/off operation and clear visual identification
- Uses dual o-ring stem seals and base seal to assure positive isolation

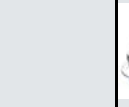
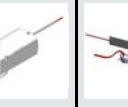



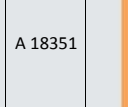
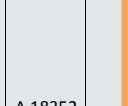



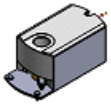
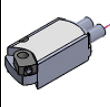
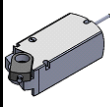
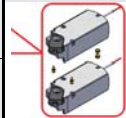

Part Number	Valve Configuration	Valve Size in	A		B		C		D		Recommended Sealing Torque		Wt	
			in	mm	in	mm	in	mm	in	mm	ft-lb	N-m	lb	kg
A 18351	Straight	1/4 - 5/8	1.33	34	1.04	26	0.16	4	0.81	21	3 - 4	4 - 5	0.08	0.04
	3-Way	1/4 - 5/8												
A 18352	** Straight	3/4 - 1 1/8	1.50	38	1.18	30	0.22	6	0.94	24	5 - 6	7 - 8	0.12	0.05
	3-Way	3/4 - 7/8												
A 18353	*** Straight	1 3/8 - 1 5/8	1.92	49	1.59	40	0.31	8	1.13	29	13 - 15	18 - 20	0.22	0.10
	3-Way	1 1/8												
A 18354	Straight	2 1/8, 2 5/8 & 3 1/8" Red Port	2.57	65	1.97	50	0.38	10	1.63	41	40 - 45	54 - 61	0.57	0.26
	3-Way	1 3/8 - 2 1/8, 2 5/8 & 3 1/8" Red Port												
A 18355	* Straight	2 5/8 & 3 1/8 Full Port	2.66	68	2.10	53	0.38	10	1.88	48	45 - 50	61 - 68	0.84	0.38
	3-Way													

Valve sizes listed are based on current standard product offering. Confirm part number requirement based on thread size.

Stem Neck Thread Size	Connection Size (in)	Straight Body No.	3-Way Body No.	Motor Series	ABV Hub Kit	ABV Hub Kit w/ Enclosure	ABV Hub/ Motor Kit	Heater	Replacement Caps			
									1 Piece Plastic	1 Piece Brass	2 Piece Brass	Retrofit Brass
												
1 1/16"-16 UN	1/4	N 02351 F 35222	----	I	A 18389	A 18389-KIT1	A 18390	---	P 36723	A 17965	A 17842	A 18351
	3/8	F 36573 F 36700	F 35222									
	1/2	F 36700A										
	5/8											
13/16"-16 UN	3/4	N 02352 F 33957 F 35223 F 35427 F 35639 F 36701 F 36701A	F 35223	I	A 18391	A 18391-KIT1	A 18392	---	P 36762	A 17966	A 17843	A 18352
	7/8											
	1 1/8	F 36702A	---									
1"-16 UN	1 1/8	N 02353 F 33958 F 35224 F 35428 F 35640 F 36702	F 35224	II	A 18393	A 18393-KIT2	A 18394	A 18366	P 36763	A 17967	A 17844	A 18353
	1 3/8	F 35949 F 36703 F 36703A	---									
	1 5/8	F 36704A	---									
1 1/2"-16 UN	1 3/8	N 02354 F 35429 F 35641	F 35162	II	A 18368	A 18368-KIT2	A 18396	A 18366	P 36764	A 17968	A 17845	A 18354
	1 5/8	N 02355 F 35430 F 35642 F 35950 F 36704	---									
	---		F 35160									
	2 1/8											
	2 5/8 Red. Port	F 35951 F 36451 F 36705 F 36705A	F 36595	III	A 18368	A 18368-KIT3	A 18395	A 18367				
	3 1/8 Red. Port											
2 5/8 Full Port	F 36706A	---	IV	A 18764	A 18764-KIT4	A 18765	A 18367 (2)					
3 1/8 Full Port	F 36322A F 36707A	---										
3 5/8, 4 1/8												
1 3/4"-16 UN	2 1/8	N 02356 F 35111	F 35161	III	A 18402	A 18402-KIT3	---	A 18367	P 36765	A 18399	A 17846	A 18355
	2 5/8 Red. Port											
	3 1/8 Red. Port											
	2 5/8 Full Port	F 35755 F 36452 F 36706	---	IV	A 18400	A 18400-KITIV	A 18401	A 18367 (2)				
3 1/8 Full Port	F 35952 F 36322 F 36707	---										
3 5/8, 4 1/8												

## Actuators

Motor Series	I	II	III	IV
Standard Actuator	P 36408 	P 36409 	P 36410 	P 36414 (2) 
Actuator with Auxillary Switch	P 36417 	P 36418 	P 36419 	P 36714 p 36889 
Hub Seal Kits	A 18403 (1 Seal) 	A 18404 (2 Seals) 	A 18404 (2 Seals) 	A 18404 (2 Seals) 

Views shown without Hub Kit Bracket Assembly. Hub Seal Kits include seals ONLY.



\* Note: Series IV motor assemblies require additional mounting hardware to join tandem motors.

## Actuator Shaft Adapter Kits

Motor Series	I	II	III	IV
Shaft Adaptor Kit (1 per box)		P 37736 	P 37735 	P 37735 
Position Indicator (10 per bag)	P 37732 	P 37731 	P 37730 	P 37730 
Shaft Adapter Clip (20 per bag)		P 37733 	P 37734 	P 37734 
Shaft Insert (10 per bag)	P 37729 			

Shaft Adapter kit includes Shaft Adapter (1), Clip (1), Position Indicator Set (1) and Screws (2).

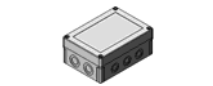
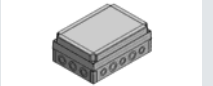
## Enclosures

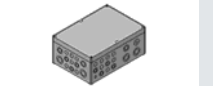
Motor Series	I	II	III	IV
Enclosure (L x W x H)	 7.1" x 5.1" x 3.0"	 10.0" x 7.1" x 4.0"	 14.2" x 10.0" x 6.0"	 14.2" x 10.0" x 6.0"

ABV Hub kit w/ Enclosure includes all the necessary accessories along with the hub kit to connect the enclosure to the hub.; Ambient Temperature (operation): -25°F to 125°F (-31°C to 51°C); Heater kit for lower temperature applications.

## O Ring Kit for Actuator Hub Service

O-Ring Kits	Valve Size
A 18403	1/2 - 1 1/8
A 18404	1 3/8 - 3 1/8



**Features:**

- Design Pressure (DP) / Maximum abnormal pressure (MAP): 775 psig, 53 bar
- Continuous operating temperature (COT): -40°F/300°F, -40°C/149°C
- Contact factory or visit website for compatibility with CFC, HCFC, HFC and HFO refrigerants and oils
- Full port construction to match line size ID
- Internally equalized ball design
- Rupture-proof encapsulated stem
- MCM Seal Technology
- UL/cUL Listed, Conforms to Pressure Equipment Directive 2014/68/EU

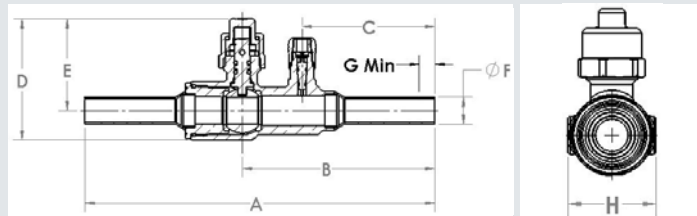

Part Number	Size		Cv	Kv	A		B		C		D		E		F		G Min		Wt		Seal Cap Kit
	in	mm			in	mm	in	mm	in	mm	in	mm	in	mm	in	mm	in	mm	lb	kg	
A 18959	1/4	6	1.0	1	6.51	165	3.62	92	2.52	64	2.23	57	1.69	43	0.25	6	0.38	10	0.69	0.31	A 17842
A 18960	3/8	10	4.0	3	6.15	156	3.44	87	2.34	59	2.23	57	1.69	43	0.38	10	0.38	10	0.61	0.28	A 17842
A 18961	1/2	13	5.0	4	6.43	163	3.54	90	2.44	62	2.23	57	1.69	43	0.50	13	0.44	11	0.59	0.27	A 17842
A 18962	5/8	17	10.0	9	6.07	154	3.36	85	2.26	57	2.23	57	1.69	43	0.63	16	0.56	14	0.62	0.28	A 17842

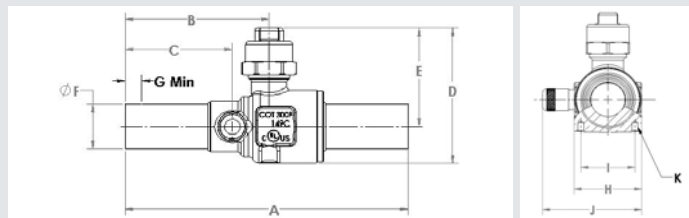

Part Number	Size		Cv	Kv	A		B		C		D		E		F		G Min		H		I		J		K		Wt		Seal Cap Kit
	in	mm			in	mm	in	mm	in	mm	in	mm	in	mm	in	mm	in	mm	in	mm	in	mm	in	mm	in	mm	in	mm	
A 18963	3/4	19	19.0	16	6.12	155	3.11	79	2.39	61	2.66	68	1.94	49	0.75	19	0.69	18	2.17	55	1.18	30	2.17	55	M4 X 0.7	0.86	0.39	A 17843	
A 18964	7/8	22	27.5	24	5.54	141	2.82	72	2.10	53	2.66	68	1.94	49	0.88	22	0.81	21	2.17	55	1.18	30	2.17	55	M4 X 0.7	0.87	0.39	A 17843	
A 18965	1 1/8	29	54.0	47	7.62	194	4.15	105	3.10	79	3.15	80	2.15	55	1.13	29	0.97	25	2.58	66	1.50	38	2.58	66	M4 X 0.7	1.65	0.75	A 17843	
A 18966	1 3/8	35	89.0	77	7.74	197	4.10	104	3.06	78	3.75	95	2.55	65	1.38	35	1.03	26	2.86	73	1.89	48	2.86	73	M4 X 0.7	2.37	1.07	A 17843	