

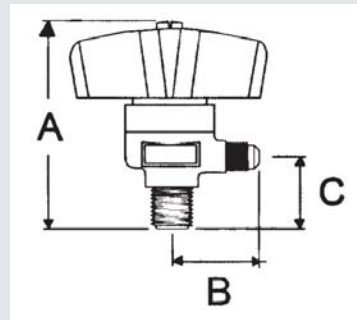

Features:

- Design Pressure (DP) / Maximum abnormal pressure (MAP) with the flow in the direction of the arrow on the body: 700 psig, 48 bar
- Design Pressure (DP) / Maximum abnormal pressure (MAP) with the flow against the direction of the arrow on the body: 350 psig, 24 bar
- Continuous operating temperature (COT): -40°F/300°F, -40°C/149°C
- Contact factory or visit website for compatibility with CFC, HCFC, HFC and HFO refrigerants and oils
- UL/cUL Listed, Conforms to Pressure Equipment Directive 2014/68/EU
- Forged brass body with full size openings for maximum flow and minimum pressure drop
- Diaphragms for positive isolation
- Thermally stable hand wheel for operation in wide temperature ranges



NPTFE to Flare

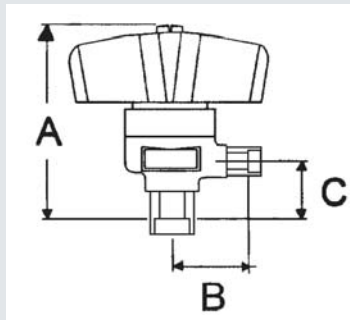

Solder to Solder

NPTFE to Flare

Part Number	NPTFE		Flare		A Open		B		C Min		Wt	
	in	mm	in	mm	in	mm	in	mm	in	mm	lb	kg
A 15525	1/4	6.35	1/4	6.35	2.82	72	1.30	33	1.04	26	0.71	0.32
A 15526	1/4	6.35	3/8	9.52	2.82	72	1.42	36	1.04	26	0.45	0.20
A 15530	1/2	12.7	1/2	12.7	3.70	94	1.86	47	1.44	37	1.17	0.53
A 15531	1/2	12.7	5/8	15.87	3.70	94	1.94	49	1.44	37	1.18	0.54

Solder to Solder

Part Number	OD		A Open		B		C		Wt	
	in	mm	in	mm	in	mm	in	mm	lb	kg
A 15539	1/4	6	2.85	72	1.11	28	0.76	19	0.69	0.31
A 15541	1/2	13	3.70	94	1.56	40	1.06	27	1.14	0.52
A 15542	5/8	17	3.70	94	1.44	37	0.94	24	1.14	0.52



Features:

- Design Pressure (DP) / Maximum abnormal pressure (MAP) with the flow in the direction of the arrow on the body: 700 psig, 48 bar
- Design Pressure (DP) / Maximum abnormal pressure (MAP) with the flow against the direction of the arrow on the body: 350 psig, 24 bar
- Continuous operating temperature (COT): -40°F/300°F, -40°C/149°C
- Contact factory or visit website for compatibility with CFC, HCFC, HFC and HFO refrigerants and oils
- UL/cUL Listed, Conforms to Pressure Equipment Directive 2014/68/EU
- Forged brass body with full size openings for maximum flow and minimum pressure drop
- Diaphragms for positive isolation
- Thermally stable hand wheel for operation in wide temperature ranges

Flare to Flare

Part Number	Size		A Open		B		C		D		Wt	
	in	mm	in	mm	in	mm	in	mm	in	mm	lb	kg
A 14833	1/4		2.70	69	1.32	34	1.38	35	0.62	16	0.59	0.27
A 14835	3/8		2.70	69	1.36	35	1.42	36	0.62	16	0.60	0.27
A 14836	1/2		3.46	88	1.62	41	1.86	47	0.84	21	1.03	0.47
A 14837	5/8		3.46	88	1.70	43	1.93	49	0.84	21	1.05	0.48

Solder to Solder

Part Number	Size		A Open		B		C		D		Wt	
	in	mm	in	mm	in	mm	in	mm	in	mm	lb	kg
A 14838	1/4	6	2.70	69	1.04	26	1.10	28	0.62	16	0.57	0.26
A 14840	3/8	10	2.70	69	1.04	26	1.10	28	0.62	16	0.57	0.26
A 14841	1/2	13	3.49	89	1.32	34	1.56	40	0.84	21	0.97	0.44
A 14842	5/8	17	3.49	89	1.20	30	1.44	37	0.84	21	1.00	0.45

Solder to Solder Ext Ends

Part Number	Size		A Open		B		C		D		Wt	
	in	mm	in	mm	in	mm	in	mm	in	mm	lb	kg
A 14848	1/4	6	2.70	69	2.66	68	2.72	69	0.62	16	0.86	0.39
A 14850C	3/8	10	2.70	69	2.82	72	2.88	73	0.62	16	0.62	0.28
A 14851	1/2	13	3.49	89	3.04	77	3.28	83	0.84	21	1.06	0.48
A 14852	5/8	17	3.49	89	3.11	79	3.35	85	0.84	21	1.17	0.53

Purge and Drain

Part Number	Size		A Open		B		C		D		Wt	
	in	mm	in	mm	in	mm	in	mm	in	mm	lb	kg
A 18997	3/8	10	2.70	69	1.42	36	1.07	27	0.62	16	0.65	0.29
A 18998	1/4	6	2.70	69	1.38	35	1.07	27	0.62	16	0.58	0.26

